

**Sri – Om**  
**VEDIC MATHEMATICS AWARENESS YEAR**

E-Newsletter Issue no 65 dated 24-12-2014

For previous issues and further more information visit at [www.vedicganita.org](http://www.vedicganita.org)

*'Credit goes to Swami Bharti Krshna Tirtha Ji Maharaj to focus the attention of present generation about the values of Ganita Sutras (mental Mathematics Sutras)'*

*All are invited to join Awareness program*

*All are warmly invited to join the awareness program of Vedic Mathematics. All teachers, parents and students are invited to Learn and Teach Vedic Mathematics for proper intelligence growth at School.*

Dr. S. K. Kapoor  
Sh. Rakesh Bhatia  
Sh. Bhim Sein Khanna  
Sh. Deepak Girdhar  
- Organizers

**ISSUE NO 65**

Page

Divine Song: Srimad Bhagwad Geeta	01-12
Lesson 01 cube (📐)	13-14
News and information News Seminar on 25 – December, 2014 Documents & photographs	15-16

*Vedic mathematics, Science &  
Technology*  
**UNIVERSITY CONCEPT**

---

---

**I**

**OPENING STATEMENT**

[(Source Theme) **To chase parallel to jyoti flow within rays of the Sun]**

---

---

**II**

**EMERGENCE AND DISSOLUTION  
OF TRILOKI (3, 4, 5, 6)**

(Source Theme) **Triloki is of transcendental (5-space) state within Jyoti**

---

---

**III**

**Existence within Human Frame**

(Source Theme) **Pursha, Sun, Atman, Vishnu are of parallel formats**

---

---

**IV**

**Sankhiya Nishtha and Yoga Nishtha**

(Source Theme) **Parallel are the formats of artifices of numbers and Dimensional frames**

---

---

**V**

**Interlinking of classical alphabets  
with Sanskrit alphabet**

(Source Theme) **Sunlight base of Devnagri alphabet**

---

---

## VI Divine Song: Srimad Bhagwad Geeta

(Source Theme) **Essence is 'Essence of Essence'**

1. Vedic Systems' essence reaches Vedanta, essence of Vedas.
2. Essence of essence reaches *Vedanta trai* 'वेदान्त त्रयी' 'Upanishads, Brahamsutra and Srimad Bhagwad Geeta'.
3. Essence of 'essence of essence' is Srimad Bhagwad Geeta 'divine song'.
4. 'Divine song' is transcendental essence, transcending manifested creations.
5. Transcendental essence transcends manifested creations by riding transcendental carriers.
6. Transcendental carriers carry 'essence' along flow format of sun-light'.
7. Transcendental flow path manifests along the format of hyper cube 5, a four fold manifestation layer (3, 4, 5, 6) with summation value  $3 + 4 + 5 + 6 = 18$ , which is further parallel to 18 transcendental yoga stops of Divine Song (18 chapters of Srimad Bhagwad Geeta).
8. These 18 transcendental yoga stops and ranges thereof, internal organizations formats features, values, virtues and order of each of these stops, deserve to be assimilated.
9. VMS & T University is to visit and re-visit these stops to help assimilate these transcendental virtues lively along the flow format of Sun-light.
10. Each organization feature of Srimad Bhagwad Geeta deserve to be comprehended well, for proper appreciation to have complete imbibing thereof to attain full insight of transcendental carriers Phenomenon parallel to flow format of Sunlight.
11. First aspect of this flow path is the set of 18 features manifesting as the initiation points of organization / titles of 18 chapters of Srimad Bhagwad Geeta. It would be blissful to comprehend that these are of the features which permit depiction as:

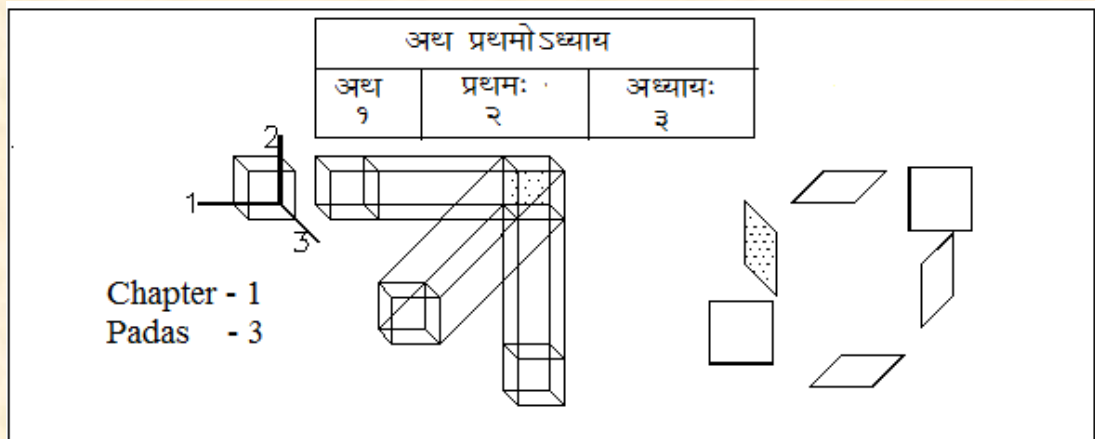



Chapters - 1 to 5

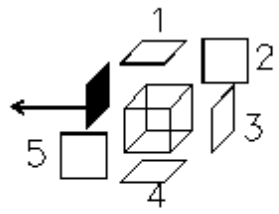

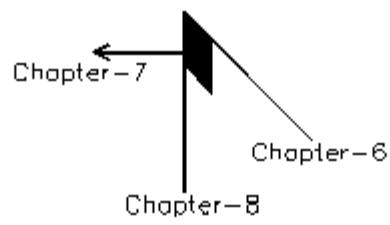
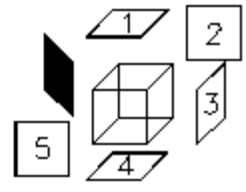

Chapters	Padas	Aksharas
1	3	7
2	3	7
3	3	7
4	3	7
5	3	7

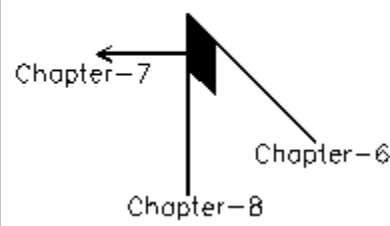
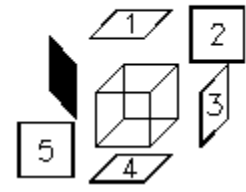
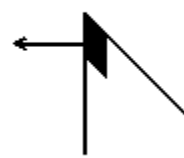



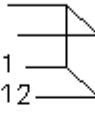
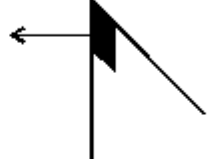

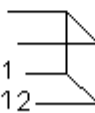
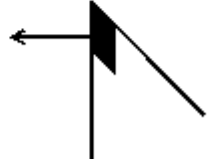



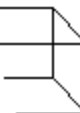
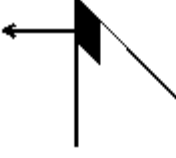

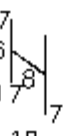

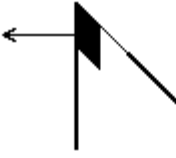
Chapters	Padas	Aksharas
6	3	6
7	3	7
8	3	6

Chapters	Padas	Aksharas	Chapter: 6 - 8	Chapter: 1 - 5
9	3	7		
10	3	7		
11	3	7		
12	3	7		
Chapter-9 Chapter-10 Chapter-11 Chapter-12				

Chapters	Padas	Aksharas	Chapter: 9 - 12	Chapter: 6-8	Chapter: 1-5
13	3	8	Chapter-9 Chapter-10 Chapter-11 Chapter-12 		
14	3	8			
15	3	8			
Chapter-13 Chapter-14 Chapter-15  Solid contents $2 \times 2 \times 2 = 8$			Chapter-9 Chapter-10 Chapter-11 Chapter-12 		

Chapters	Padas	Aksharas	Chapter 13-15	Chapter 9-12	Chapter 6-8	Chapter 1-5
16	3	7				
17	3	8				
18	3	7				
Chapter-16 Chapter-17 Chapter-18 						

Chapters	Padas	Aksharas	
1	3	7	
2	3	7	
3	3	7	
4	3	7	
5	3	7	
6	3	6	
7	3	7	
8	3	6	
9	3	7	
10	3	7	
11	3	7	
12	3	7	
13	3	8	
14	3	8	
15	3	8	
16	3	7	
17	3	8	
18	3	7	

12. From this initiation stage to the eighteen pushpikas stage of 18 chapters of Srimad Bhagwad Geeta is a long range of organization features, which deserve to be chased step by step.

13. Pushpikas stage is the conclusive stage and it permits chase depiction as under:

Pushpika

Chapters	Padas	Aksharas
1	13	48

Pushpika

Chapters	Padas	Aksharas
2	13	45
3	13	45

Chapters-2

Chapters-3

$9 \times 5 = 45$

Pushpika

Chapters	Padas	Aksharas
4	13	50

$10 \times 5 = 50$

Pushpika

Chapters	Padas	Aksharas
5	13	48

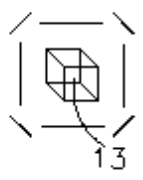





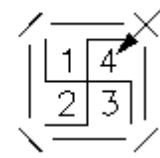



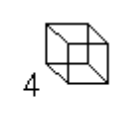

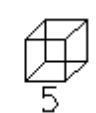





Pushpika

Chapters	Padas	Aksharas
6	13	47



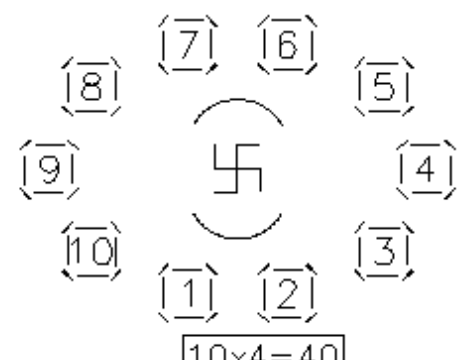

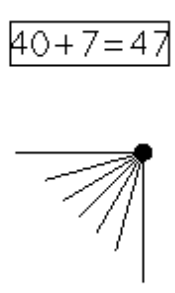

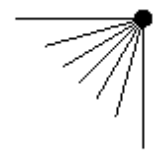

Pushpika

Chapters	Padas	Aksharas
7	13	48

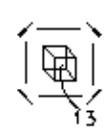

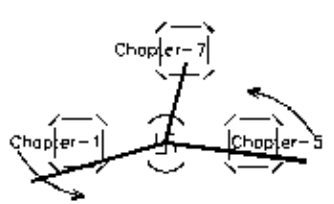

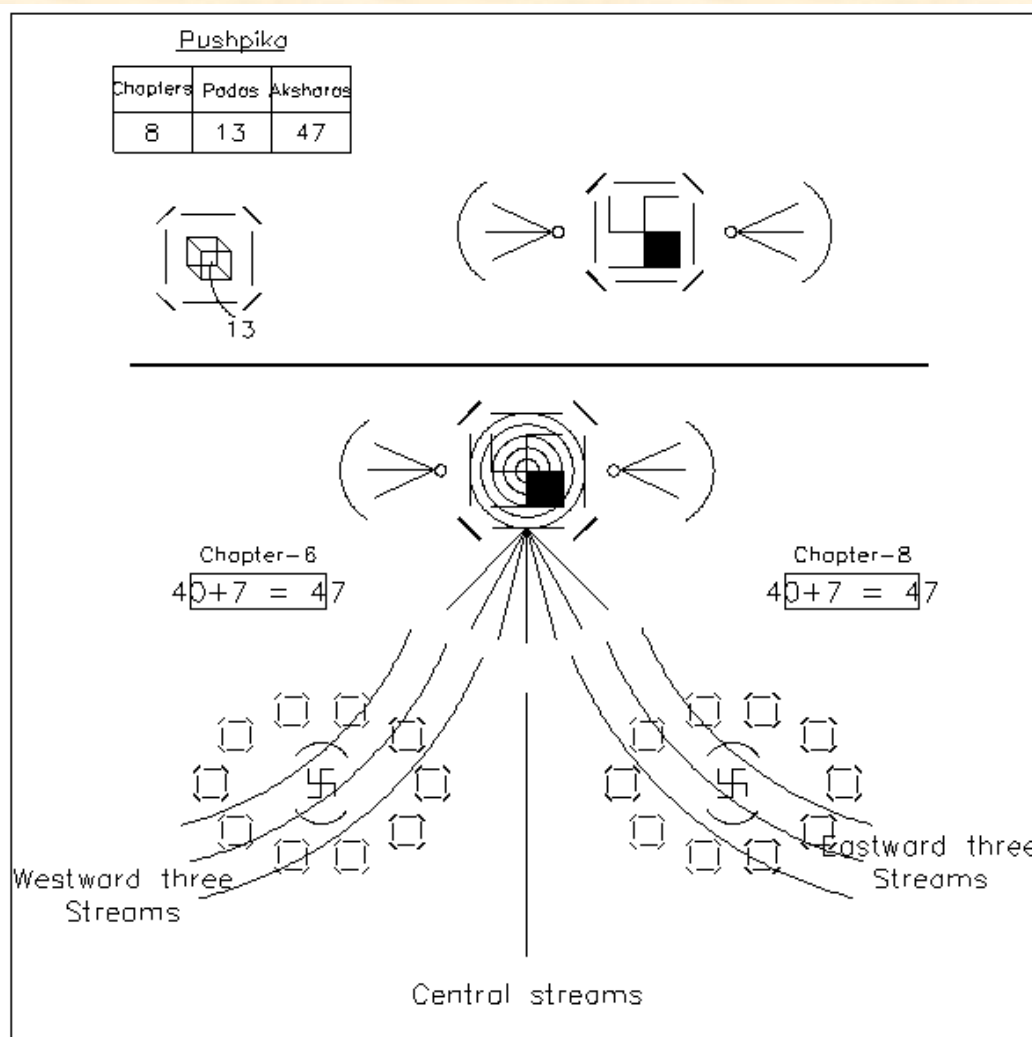
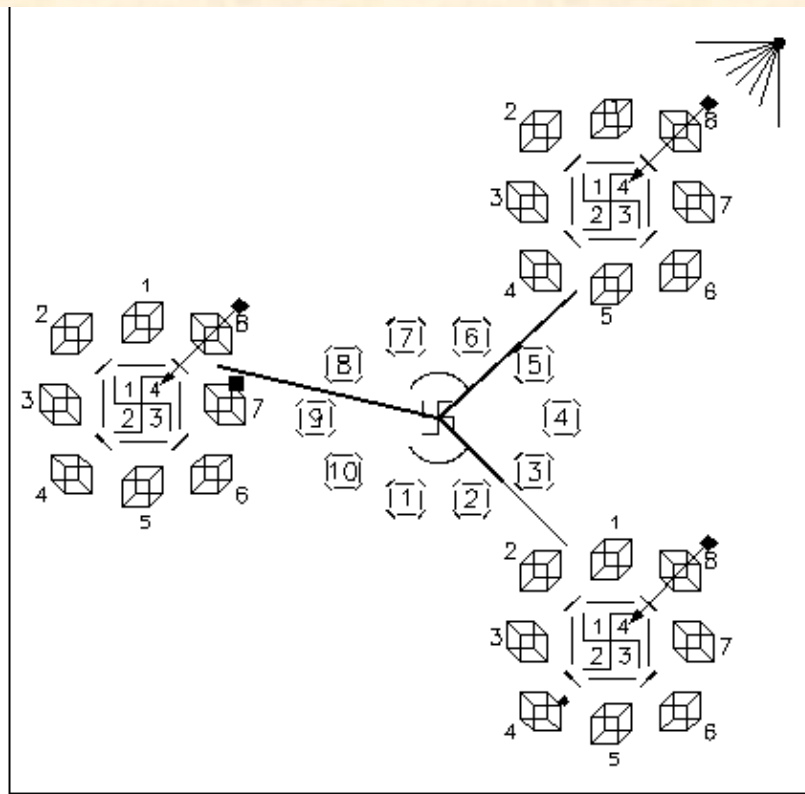

Pushpika

Chapters	Padas	Aksharas
8	13	47

Positional - values

17
18
19

---

$17 \times 3 = 51$

Pushpika

Chapters	Padas	Aksharas
10	13	46

---

$40 + 6 = 46$

$10 \times 4 = 40$



Pushpika

Chapters	Padas	Aksharas
11	13	50

---

Pushpika

Chapters	Padas	Aksharas
12	13	45

$9 \times 5 = 45$

Pushpika

Chapters	Padas	Aksharas
13	13	52

$9 + 4 = 13$

$13 \times 4 = 52$

Pushpika

Chapters	Padas	Aksharas
14	13	51

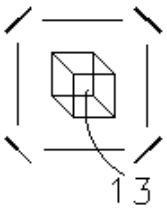

13

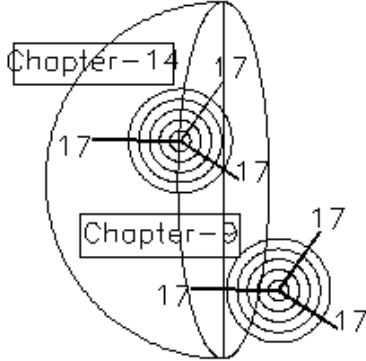

Chapter-14

Chapter-9

17

17



$17 \times 3 = 51$

Pushpika

Chapters	Padas	Aksharas
15	13	49

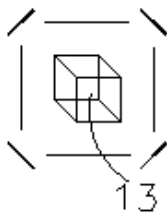

13

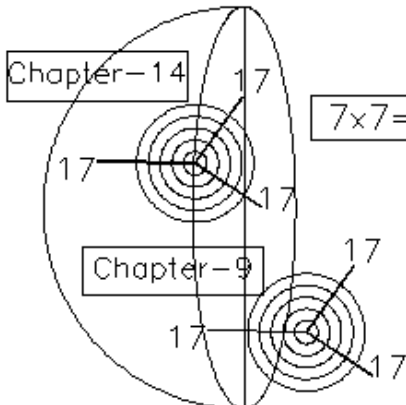

Chapter-14

Chapter-9

17

17

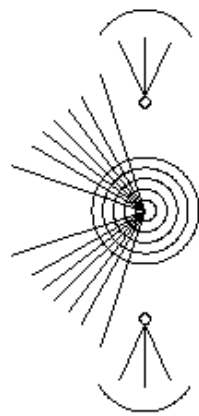

$7 \times 7 = 49$

$17 \times 3 = 52$

Pushpika

Chapters	Padas	Aksharas
16	13	52

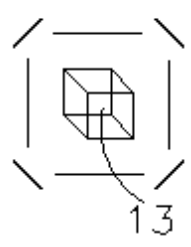

13

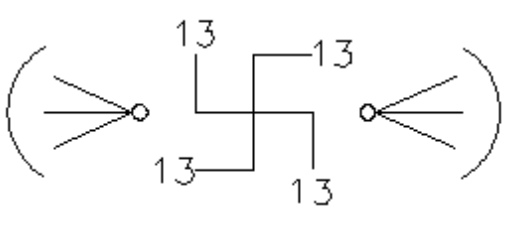
$9 + 4 = 13$ 

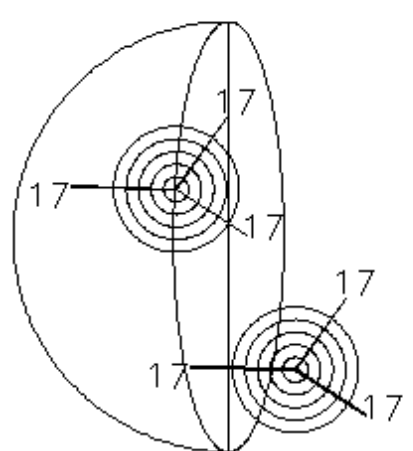

Chapter-13

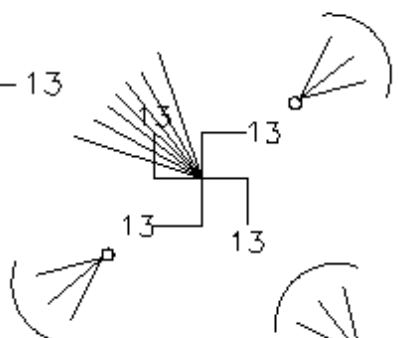

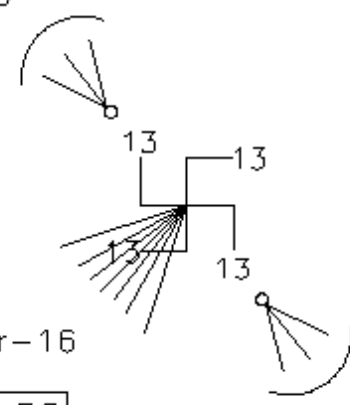

Chapter-16

$17 \times 3 = 52$

Pushpika

Chapters	Padas	Aksharas
17	13	51

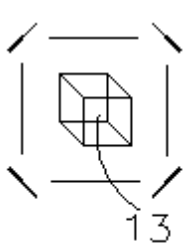

13

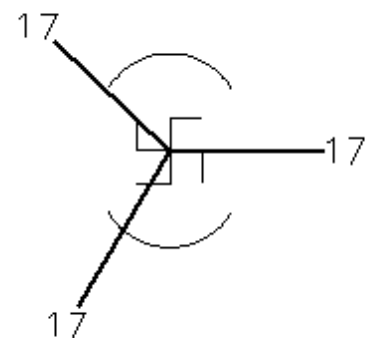

$17 \times 3 = 51$

Pushpika

Chapters	Padas	Aksharas
18	13	48

13

\*

**24-12-2014**

Dr. S. K. Kapoor, *(Ved Ratan)*

*VMS & T Project*  
*School Text Books*  
*(Class IX, X, XI & XII)*

-----  
*VMS & T Text Book Class IX*  
*(3-space)*

Lesson - 01  
Cube (📐)

1. Cube (📐) is the representative regular body of 3-space.

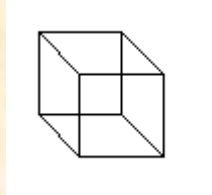

2. Representative body is one which does not distinguish / prefer one dimension over another dimension.  
 3. 3-space accepts three linear dimension frame for its bodies

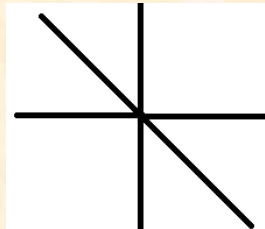

4. Linear dimension accepts 'length' as a 'unit'; pair of linear dimensions (designated as length unit and breadth unit respectively) accept 'area' as a unit, and all the three dimensions (designated as a length unit, breadth unit and height unit respectively) accept as 'volumme unit'.  
 5. The common point ( joint) of three dimensions (of length, breadth and height units) is designated as origin of a three dimensional frame of linear dimensions.  
 6. Centre of cube (📐) super imposes upon origin of three dimensional frame.

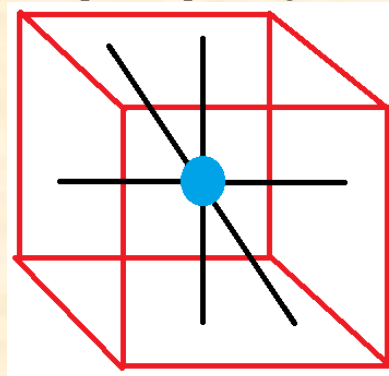

7. The set up of 'cube' with its centre super imposed upon the origin of a three dimensional frame and each dimension coordinates the centres of a pair of parallel surface plates of cube makes complete set up of regular body of 3-space.
8. The complete set up of cube (☐) as such makes out a set of 31 geometric components, namely
  - (i) 8 corner points of cube (☐)
  - (ii) 12 edges of cube (☐)
  - (iii) 6 surfaces of cube (☐)
  - (iv) 1 volumme of cube (☐)
  - (v) 3 dimensions of 3 dimensional frame

Total  $8 + 12 + 6 + 1 + 3 + 1 = 31$  structural (geometric) components

Exercises

I. Define and tabulate different conceptual of technical terms of lesson

Hint : Cube (☐), representative regular body, 3-space, dimension, origin, dimensional frame, corner point, edge, surface, volumme & centre of cube, length, breadth & height units, length area and volume units, complete set up of cube, structural geometric components, etc.

II. Visit and revisit the following :

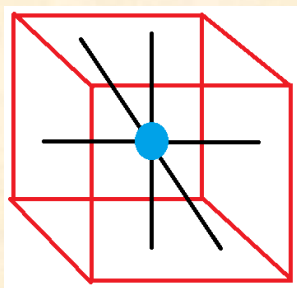

=

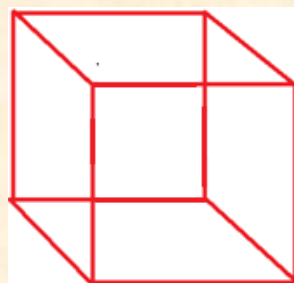

+

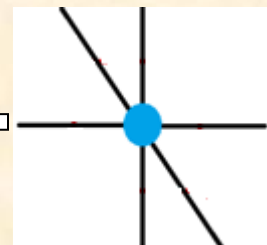

3 + 1

NVF (Cube) = 31  
TCV (घनः)= 27

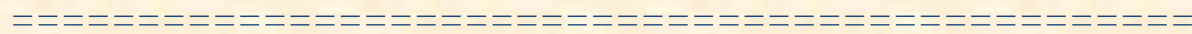

\*

24-12-2014

Dr. S. K. Kapoor, (Ved Ratan)

## *News and Information*

### **News**

It is for intimation that inadvertently, there has been incorrectness regarding the price of the following books in issue no 64. The correct information is as under regarding the books authored by Kenneth Raymond Williams.

Please note these prices include postage to anywhere in the world.

Quoted from [www.vedicmaths.org](http://www.vedicmaths.org) website:

<http://www.vedicmaths.org/shop/books>

Clicking on a book title will give more information about its contents etc.

The books do not have outlets in India, but as they were published in India until a few years ago it may be possible to obtain copies in Indian bookshops.

Sn.	BOOK	price in \$, USD
1	Cosmic Computer course	75
2	VM Teacher's Manual 1 (2002)	28
3	VM Teacher's Manual 2 (2002)	33
4	VM Teacher's Manual 3 (2003)	36
5	The Natural Calculator (1991)	15
6	Discover Vedic Mathematics (1984)	33
7	Triples (1984)	36
8	Vertically and Crosswise (1984)	33
9	Astronomical Appls of VM (2000)	28
10	Why do we Calculate Backwards?	15
11	The Circle Revelation	30
12	VM Proofs	25
13	The Crowning Gem	25

\*

### *Seminar on 25 – December, 2014*

Dr kailash vishwkarma ji ke dwara ek karyashala on 25 dec 9:30 am to 1:30 pm tak nyas karyalay narayna me rahegi jisme vedic ganit padhaya jayega ,bhojan rahega. Prant ki toli ,anya ganit premi sabhi ka swagat he . Shulk 50/-Rs rahega.

\*

*Documents & photographs*

$$1729 = 12^3 + 1^3 = 10^3 + 9^3$$

$$4104 = 16^3 + 2^3 = 15^3 + 9^3$$

$$13832 = 24^3 + 2^3 = 20^3 + 18^3$$

$$20683 = 27^3 + 10^3 = 24^3 + 19^3$$

Srinivasa Ramanujan's  
Birthday Magic Square

22	12	18	87
59	57	15	8
38	17	50	34
20	53	56	10



24-12-2014

Sh. Rakesh Bhatia  
Sh. Bhim Sein Khanna  
Sh. Deepak Girdhar  
Organizer